

STATIONARY COMPACTORS

445HD & 445XHD

Wastequip's efficient, powerful, and long-lasting industrial 4-yard compactor has a large 65" x 60" clear top opening, and is ideal for dry waste and recycling material.



Guardian™ Control System

- New user-friendly controls
- Automatic Maintenance Tracking
- Superior 24-volt control
- NEMA 4 rated enclosure
- Remote power unit with weather protection cover

Heavy-Duty Ratchet Binders

- 1" thick hooks
- Greasable fittings

Performance

- 14" ram penetration minimizes spring-back of material
- Heavy-duty 8" x 8" x 1" breaker bar

Large-Access Openings for Maintenance and Service

- Removable rear panel
- Removable side panels



Easy-to-use 24-volt Guardian Control System (optional remote pendant shown)

** Use of an oil heater or extreme cold weather hydraulic oil is recommended in extreme cold conditions.*

STATIONARY COMPACTORS

445HD & 445XHD

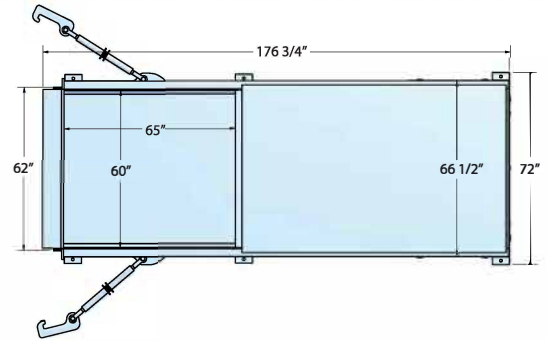
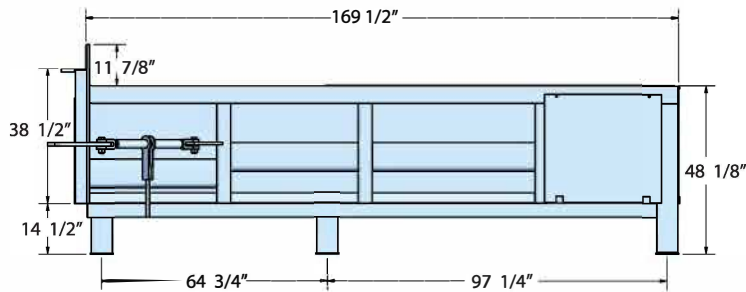

Standard Features

- 1/2" thick ram floor
- 57-second cycle time
- Controls in panel face
- Automatic Maintenance Tracking
- Full container light
- Low temperature oil
- Multi-cycle timer
- Operational and service manual
- NEMA 4 control panel protects against windblown dust, splashing water, and hose-directed water
- Primed and painted in multiple colors
- Remote power unit with weather cover

Options

- Advance warning light
- Color-coded pressure gauge
- Guide rails with/without stops
- Oil heater
- Photo electric eye
- Odor control system
- Cart dumper
- Biodegradable oil

Warranty

- 3-1-1 warranty (3-year structural, 1-year parts, 1-year labor)

Specifications

		445HD	445XHD*
Charge Box	Wastequip rating	4.00 cu. yds.	
	Wastec rating	2.59 cu. yds.	
	Clear top opening	65" Length x 60" Width	64" Length x 60" Width
	Compactor weight with power unit	6,700 lbs.	6,900 lbs.
Ram	Ram height	30.50"	
	Ram penetration	14.00"	
	Face plate	1/2" steel with 3/4" stiffener plates	
	Base plate	3/8" steel with 10 gauge formed stiffeners	
	Top plate	1/4" steel with 10 gauge formed stiffeners	
	Side plates	1/4" formed plate	
Compactor Head	Floor	1/2" steel with 10 gauge channels at 12" spacing	
	Sides	1/4" steel formed vertical stiffeners and formed horizontal stiffeners	1/4" steel formed vertical stiffeners and formed horizontal stiffeners; side stiffeners, gussets in discharge area
	Breaker bar	8" x 8", 1" angled steel	1" thick breaker bar plate
	Top deck	12 gauge steel (standard)	
Electrical	Electric motor, fan cooled	15 hp	
	Voltage	208/230/460, 3 phase 60 Hz	
	Power box	UL rated, TEFC housing	
	Automated cycle operation	Push-button start extends, retracts & stops automatically	
Hydraulic Performance	Pump	16.4 gpm	
	Pump type	Fixed gear	
	Hydraulic oil tank	25-gallon reservoir	
	Cylinder bore/rod/stroke	6.25" bore, 4.75" rod, 80" stroke	
	Normal ram face pressure	52,100 lbs.	64,400 lbs.
	Max. ram face pressure	56,500 lbs.	70,500 lbs.
	Normal ram psi	28.47 psi	35.19 psi
	Maximum ram psi	31.80 psi	38.52 psi
	Cubic yards per hour	164	
	Power unit location	Remote	
Cycle time	57 seconds		

* Specifications are the same as the 445HD, except where indicated.



Replacement parts available online at www.wastebuilt.com

Standard Color Choices



Colors shown are as accurate as printing allows. The actual color is subject to variation from the printed color sample. Color choices vary by plant location. Please contact your local sales representative for available colors. Custom colors are available upon request and are subject to an additional charge.



Tel: 877.468.9278 | sales@wastequip.com | www.wastequip.com

Wastequip is the leading North American manufacturer of waste and recycling equipment for collecting, processing, and transporting recyclables and solid or liquid waste. © Wastequip. All rights reserved. Specifications subject to improvement without notice. Equipment displayed should be operated by properly trained personnel. Operators should become familiar with OSHA, ANSI, and any other applicable standards or laws for using this equipment. Improper use, misuse, or lack of maintenance could cause injury to people and/or property. Photos used in the literature are illustrative only. We assume no liability or responsibility for proper training/operation of equipment not manufactured by Wastequip. We reserve the right to make changes at any time without notice. Information contained within this literature is intended to be the most accurate available at time of printing.